

RG78SB 16Vin Switching Voltage Regulators

General Description

The RG78SB family of switching regulators incorporate all of the devices needed to make a modern, high efficiency, step-down switching regulator in a 3 pin SIP package which is pin compatible with industry standard T0-220 LM78xx regulators. These regulators employ internal cycle-by-cycle current limiting, and free convection cooling (no forced airflow).

Custom output voltages available from 1.25 to 5.5 Volts

Features

- Output current to 2 Amps, no heatsinking
- High efficiency
- Very low noise - 30mVp-p typical at 16Vin
- No external components required
- Output Voltage from 1.25Volts to 5.5 Volts
- Excellent transient response
- Exceptional line and load regulation
- Short circuit limited

Typical Application

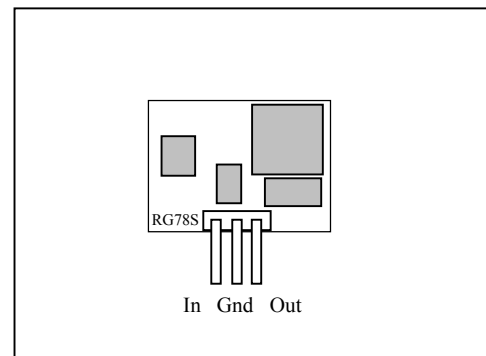
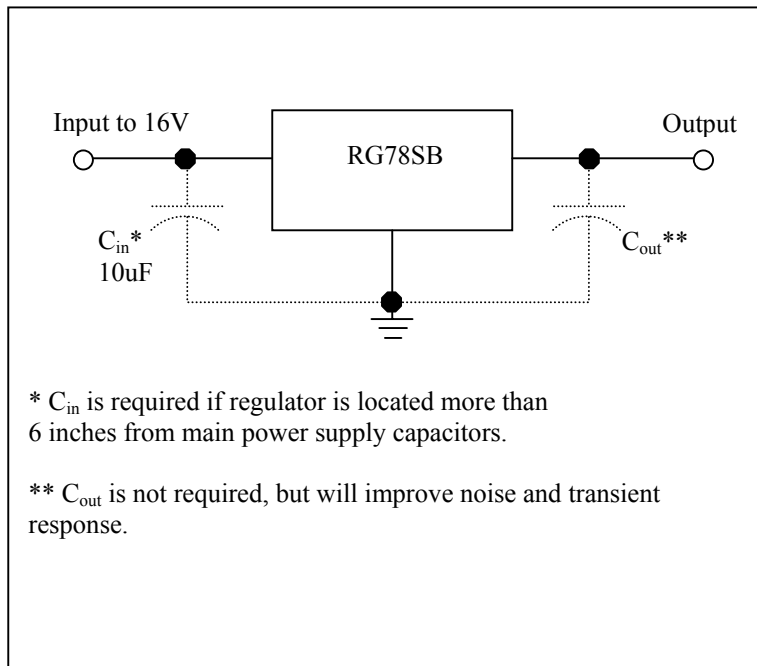

Standard P/N	Output Voltage
RG78SB033	3.3V
RG78SB050	5.0V

Absolute Maximum Ratings

Input Voltage	16
Power Dissipation	1.25 Watts
Operational Temperature Range	0C to +70C
Storage Temperature Range	-25C to +150C
Lead Temperature (Soldering, 5 Sec)	260C

Electrical Characteristics

RG78SB050 5.0V $T_a = 25C$ (unless otherwise noted)

Symbol	Parameter	Conditions	Min	Typ	Max	Unit
V_{in}	Input Voltage	0C to 70C	6.5		16.0	V
V_o	Output Voltage	$I_o = 1.5A, V_{inmin} < V_{in} < V_{inmax}$	4.900	5.0	5.100	V
V_n	Output Noise and Ripple	$V_{in} = V_{inmax}, I_o = I_{omax}$		30		mVp-p
I_{min}	Minimum Output Current			0		mA
I_{omax}	Maximum Output Current	Continuous, 0C to 70C	2.0			A
I_{sc}	Short Circuit Current Limit	Note 1		2.5		A
I_{scf}	Short Circuit Current Limit Recovery	0C to 70C, Note 2	1.8			A
I_q	Quiescent Current	$I_o = 0, V_{in} = V_{inmax}, 0C$ to 70C		0.3	1.0	mA
% V_o/V_{in}	Line Regulation	$V_{inmin} < V_{in} < V_{inmax}, 0C$ to 70C			0.6	%
% V_o/I_{out}	Load Regulation	$I_{omin} < I_o < I_{omax}, 0C$ to 70C			1	%
t_{tr}	Transient Response Recovery Time	$I_o: 10\% \rightarrow 90\% \rightarrow 10\%$ of I_{omax} . 1us fall/rise time. $V_{in} = V_{inmax}$		100		us
V_{tr}	Transient Response Over/Under Shoot	$I_o: 10\% \rightarrow 90\% \rightarrow 10\%$ of I_{omax} . 1us fall/rise time. $V_{in} = V_{inmin}$		5		% V_o
F_{sw}	Switching frequency	$I_{omin} > 200mA$, Note 3		250		Khz
η	Efficiency	$V_{in} = 16V, V_o = 5.0V, I_o = 1.5A$		90		%

Note 1: During Current Limit operation, the output voltage and operating frequency drop significantly.

Note 2: Once Current Limiting is active, the load must be reduced below this amount before normal regulation resumes.

Note 3: Switching frequency varies with V_{in} and load current, approximately 70Khz to 350Khz.

Application Information

This section shows examples of measurement data of the DC/DC modules; output voltage stability, efficiency, input and output noise, and transient response with a step-current load change.

RG78SB050 5.0V Ta=25C

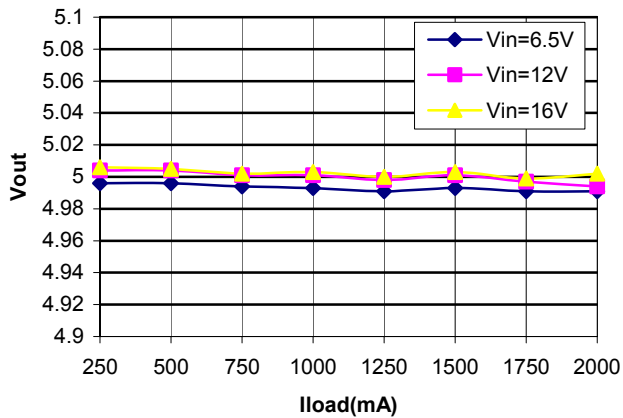

Line and Load Regulation

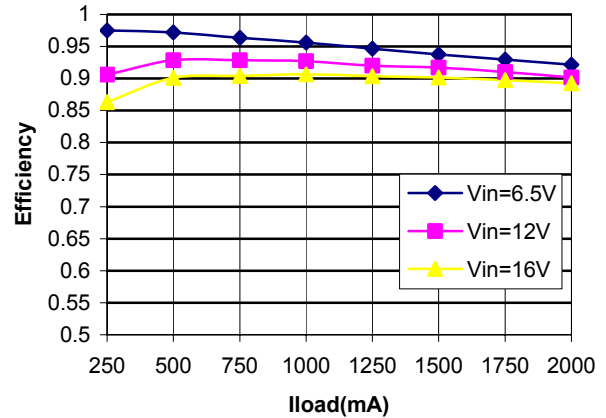

Efficiency

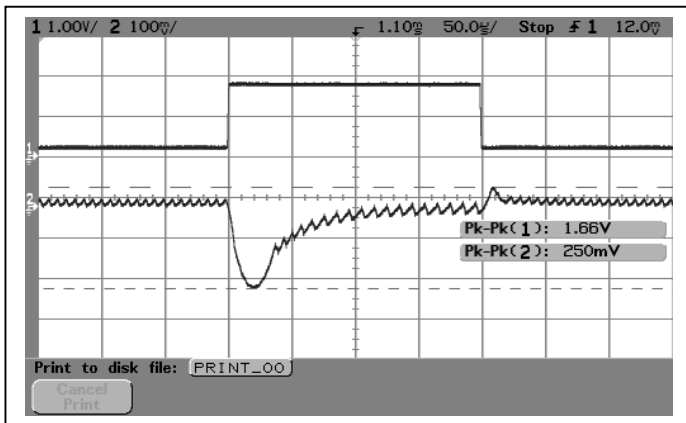

Output voltage transient response (bottom) with load current (top). The load current steps from 200mA to 1.8A to 200mA. Vin = 6.5V, measurement bandwidth is 20MHz.

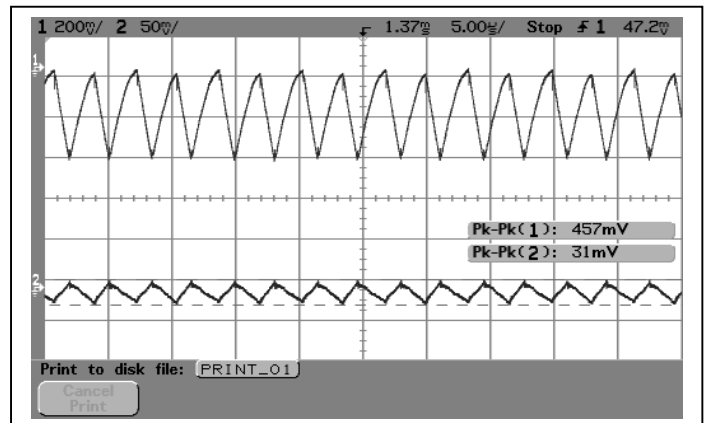

Output voltage noise/ripple (bottom) and input voltage noise/ripple (top) with 2A load current and 16V input voltage. The measurement bandwidth is 20MHz.

Mechanical Data

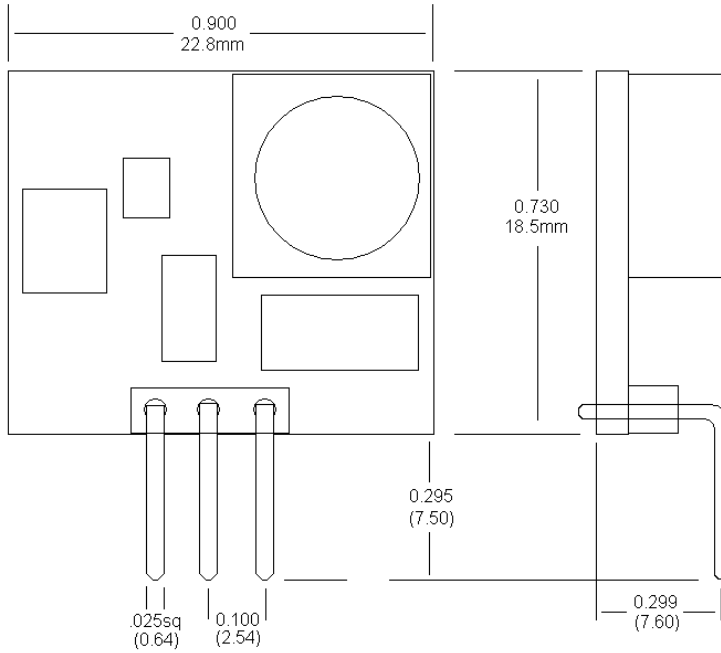

3 pin SIP (vertical mount)

Ordering Information

